

NOTES:

- DO NOT SCALE. USE FIGURED DIMENSIONS ONLY.
- THIS DRAWING IS TO BE READ IN CONJUNCTION WITH ALL OTHER RELEVANT ARCHITECTURAL AND ENGINEERING DRAWINGS.
- WATERMANS SHALL BE LAID IN ACCORDANCE WITH THE LOCAL AUTHORITY /IRISH WATER SPECIFICATION FOR THE LAYING OF NEW WATERMANS AND BYLAWS WHICH OVER-RIDE THESE NOTES. THE CONSTRUCTION OF THE WATERMAIN SHALL BE IN ACCORDANCE WITH THE BEST CURRENT PRACTICE AND THE LATEST EDITIONS OF THE RELEVANT STANDARDS AND CODES OF PRACTICE.
- WATERMANS SHALL NOT BE LAID UNDER WALLS OR AREAS DESIGNATED FOR TREES/SHRUBS/FLOWERS.
- PIPES SHALL BE HDPE (BLUE PIPE) UNLESS NOTED OTHERWISE BY AGREEMENT WITH THE LOCAL AUTHORITY. DUCTILE IRON PIPES SHALL BE USED UNDER ROADS OF CLASSIFICATION "DISTRICT DISTRIBUTOR" UPWARDS UNLESS NOTED OTHERWISE.
- PIPES SHALL CONFORM TO THE UK WATER INDUSTRY SPECIFICATION OR EQUIVALENT E.U. SPECIFICATION.
- DUCTILE IRON (DI) PIPES SHALL CONFORM TO IS EN 545 AND SHALL HAVE MINIMUM C40 PRESSURE RATING. DUCTILE IRON FITTINGS SHALL HAVE 16 BAR RATING AT LEAST DI PIPEWORK SHALL BE COATED INTERNALLY WITH A BLAST FURNACE CEMENT LINING WHICH COMPRISES WITH THE REQUIREMENTS OF BS 6920. EXTERNAL PROTECTION SHALL INCLUDE AN ALLOY OF ZINC AND ALUMINUM WITH A MINIMUM 15% ALUMINUM WITH OR WITHOUT OTHER MATERIALS HAVING A MASS OF 400g/m² COMPETE WITH A FINISHING LAYER OF BLUE FUSION BONDED EPOXY IN ACCORDANCE WITH IS EN 14901.
- WATERMANS SHALL BE LAID UNDER FOOTPATHS PREFERABLY OR GRASS MARONS WHERE APPROVED. NO PIPE, CONDUIT, CABLE OR OTHER SERVICE SHALL BE LAID LONGITUDINALLY OVER THE LINE OF A WATERMAIN. NO CABINET POLES, JUNCTION BOXES OR CHAMBERS SHALL BE CONSTRUCTED OVER A WATERMAIN.
- THE MINIMUM COVER TO A WATERMAIN SHALL BE 750mm, THE MAXIMUM COVER SHALL BE 900mm UNLESS NOTED OTHERWISE.
- CONNECTIONS TO THE MAINS WHICH ARE THE PROPERTY OF THE IRISH WATER CAN BE MADE BY THE IRISH WATER ONLY. NO OTHER PERSON MAY INTERFERE IN ANY WAY WITH THESE MAINS. SUCH CONNECTIONS WILL BE MADE BY IRISH WATER AT THE EXPENSE OF THE PERSONS REQUIRING THEM. THE ESTIMATED COST OF SUCH CONNECTIONS MUST BE LODGED WITH IRISH WATER BEFORE THE WORK IS UNDERTAKEN.
- IT IS THE CONTRACTORS RESPONSIBILITY TO ENSURE THAT ALL WORKS ARE CONSTRUCTED IN ACCORDANCE WITH THE IRISH WATER CODE OF PRACTICE AND STANDARD DETAILS. THE CODE OF PRACTICE AND STANDARD DETAILS ARE AVAILABLE TO DOWNLOAD FROM THE IRISH WATER WEB SITE AT WWW.WATER.IE/CONNECTIONS/DEVELOPER-SERVICES/ WHERE THE DETAILS CONTAINED ON THIS DRAWING DIFFER FROM THE IRISH WATER CODE OF PRACTICE OR STANDARD DETAILS THIS MUST BE BROUGHT TO THE ATTENTION OF THE ENGINEER IMMEDIATELY. IRISH WATER STANDARDS WILL TAKE PRECEDENCE.

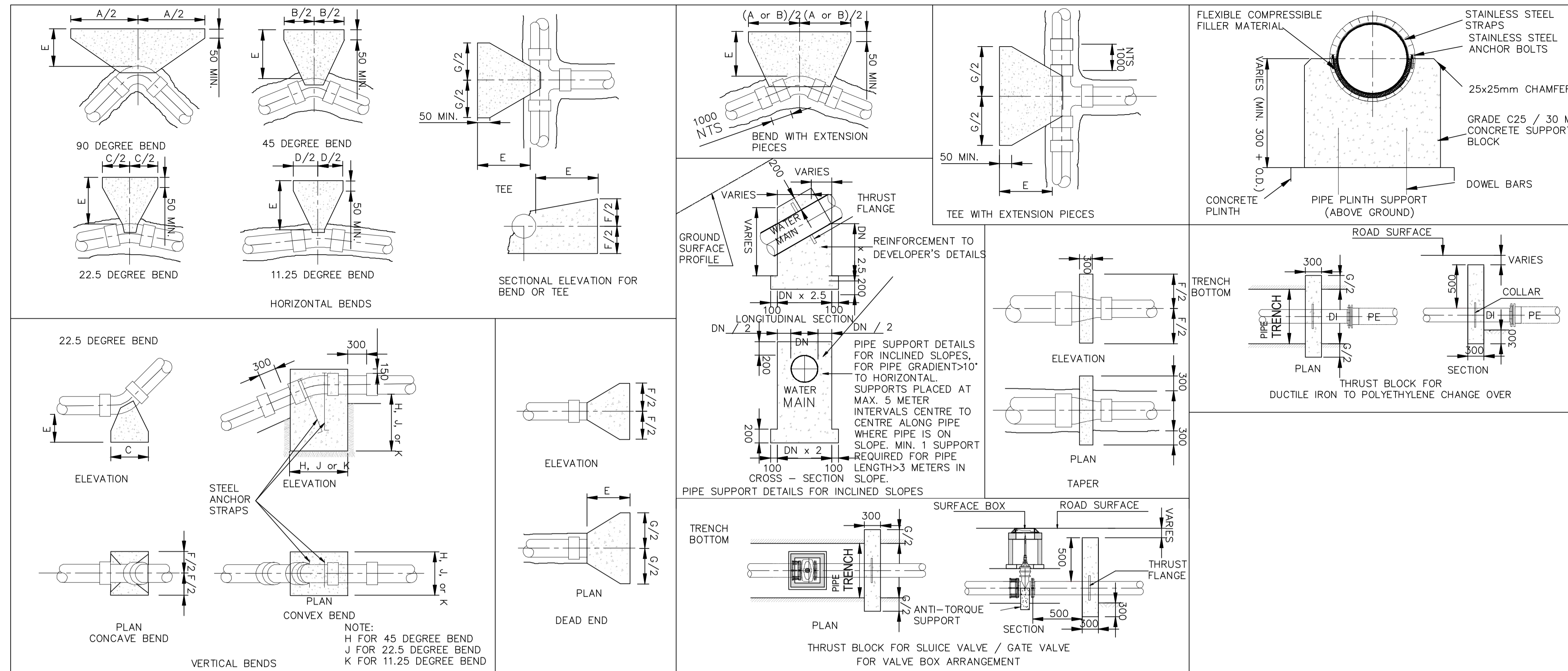

< 12 BAR TEST PRESSURE

NOM. DIA. (mm)	DIMENSIONS									
	A	B	C	D	E	F	G	H	J	K
100	600	330	180	80	200	350	390	700	800	400
150	950	510	260	130	225	450	660	900	750	800
200	1150	600	310	160	300	650	790	1050	900	700
250	1350	750	380	200	300	800	970	1200	1000	750
300	1580	850	450	220	320	950	1110	1300	1100	850
350	2100	1150	570	290	450	1000	1450	1550	1200	900
400	2550	1400	700	350	500	1050	1800	1700	1250	1000
450	3000	1630	830	420	680	1100	2130	1800	1450	1150
500	3580	1950	990	500	800	1200	2540	1950	1600	1250
600	4100	2200	1120	570	850	1400	2880	2100	1700	1300

12 BAR TO 15 BAR TEST PRESSURE

NOM. DIA. (mm)	DIMENSIONS									
	A	B	C	D	E	F	G	H	J	K
100	700	380	190	100	200	350	510	750	600	400
150	1135	620	320	160	225	450	760	950	750	600
200	1400	750	380	190	300	650	980	1150	850	700
250	1730	940	480	240	320	800	1210	1350	1050	850
300	2090	1130	580	300	380	950	1480	1500	1200	950
350	2600	1410	720	360	500	1050	1840	1700	1350	1050
400	2980	1610	820	420	750	1200	2110	1850	1500	1150
450	3400	1840	940	470	900	1300	2330	2090	1600	1250
500	4080	2210	1130	570	1000	1400	2690	2290	1750	1350
600	5010*	2710*	1380	700	1000	1500	3550*	2350	1900	1500

15 BAR TO 18 BAR TEST PRESSURE

NOM. DIA. (mm)	DIMENSIONS									
	A	B	C	D	E	F	G	H	J	K
100	750	400	205	100	220	400	530	800	650	400
150	1250	700	350	180	250	500	890	1000	850	650
200	1650	890	450	230	320	700	1170	1250	1000	800
250	1960	1060	540	270	350	900	1370	1450	1150	900
300	2300	1200	640	320	500	1100	1630	1650	1300	1050
350	2830	1580	830	410	750	1200	2070	1850	1500	1150
400	3510	1900	970	190*	1000	1300	2490	2000	1600	1250
450	3610	2270	1160	580	1000	1350	2970	2150	1700	1350
500	4340*	2380	1210	610	1000	1400	3700	2250	1750	1400
600	6370*	3450*	1760	890	1000	1500	4500*	2400	2050	1650

GRADIENT	SPACING
1 IN 2 & STEEPER	5.5m
BELOW 1 IN 2 TO 1 IN 4	11.0m
1 IN 4 TO 1 IN 5	16.6m
1 IN 5 TO 1 IN 6	22.0m

WATERMAIN THRUST AND SUPPORT BLOCKS STD-W-28

- ALL DIMENSIONS IN MILLIMETRES (mm) UNLESS NOTED OTHERWISE.
- CONCRETE THRUST BLOCKS (ANCHORAGE) SHALL BE POSITIONED SYMMETRICALLY WITH RESPECT TO THE CONNECTING PIPE & BENDS.
- TRENCH DIMENSIONS : DRAWING No's. STD-W-13.
- THRUST BLOCKS SHALL BEAR ON UNDISTURBED SOIL. IF FOR ANY REASON THEY CANNOT THEN THE DEVELOPER SHALL NOTIFY IRISH WATER IMMEDIATELY WITH A PROPOSED SOLUTION.
- THRUST BLOCK REINFORCEMENT REQUIRE SPECIFIC DESIGN.
- FOR TEST PRESSURES GREATER THAN 18 BAR, THRUST BLOCK DESIGN IS TO BE SUBMITTED TO IRISH WATER FOR APPROVAL.
- THRUST BLOCKS ARE DESIGNED FOR AN AVERAGE BEARING PRESSURE OF 100 kN/m² (TYPICAL FOR SOFT CLAY) FOR OTHER CONDITIONS. ACTUAL DIMENSIONS MAY BE ALTERED ON INSTRUCTIONS FROM IRISH WATER.
- CONCRETE IN THRUST BLOCKS SHALL BE GRADE C20/25.
- COMPRESSIBLE FILLER FOR CONCRETE PROTECTION TO BE IN ACCORDANCE WITH BS EN 622-1 AND BS EN 622-4. BITUMINOUS MATERIAL SHALL NOT BE PUT IN CONTACT WITH PLASTIC PIPES. THE THICKNESS OF COMPRESSIBLE FILLER FOR MAINS < 450mm IN DIAMETER IS TO BE 18mm.
- CONCRETE THRUST BLOCKS FOR POLYETHYLENE PIPE TO COMPLY WITH THE MANUFACTURES REQUIREMENTS.
- POLYETHYLENE PIPES SHALL BE WRAPPED IN PLASTIC SHEETING HAVING A COMPOSITION IN ACCORDANCE WITH BS 6076 BEFORE BEING CAST INTO CONCRETE.
- ALL CONCRETE TO BE IN ACCORDANCE WITH IS EN 206.

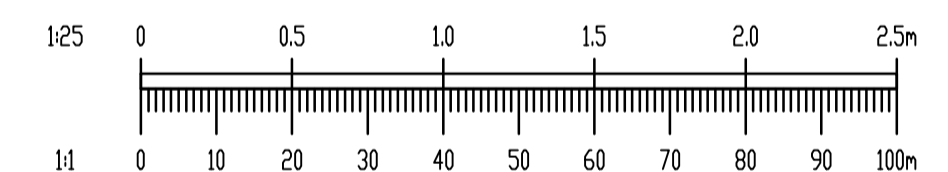

REV.	DATE	AMENDMENT	DRN	APPD

STATUS **PLANNING**

Waterman Moylan
Engineering Consultants
BLOCK 9, EASTPOINT BUSINESS PARK, ALFIE BYRNE ROAD,
DUBLIN D03 K7W7 IRELAND.
Tel: (01) 664 8900 Fax: (01) 661 3618
Email: info@waterman-moylan.ie www.waterman-moylan.ie

CLIENT **GERARD GANNON PROPERTIES**
ARCHITECT **CONROY CROWE KELLY ARCHITECTS**
PROJECT
PHASE 5, MIXED USED DEVELOPMENT, OLDTOWN, SWORDS
TITLE
WATERMAIN CONSTRUCTION DETAILS SHEET 2 OF 4

DRAWN MS	DESIGNED RM	APPROVED MD	DATE MARCH 2022
SCALE 1:25 @ A1	JOB NO. 17-144	DRG. NO. P1321	REVISION